

***Russian Regulators: Part I
“The Early Years”
PP-1/-30/-31 & -31A
for the
Г-11/-11A 7-Amp Generator***

***Ernie Franke
eaf Franke@tampabay.rr.com***

6-Volt Electro-Magnetic (Relay-Type) Regulator (PP-1/-30/-31/-31A) for the Г-11/-11A 7-Amp Alternator

- **Background**
 - **Voltage Regulators Paired with Specific Generators/Alternators**
 - **Time-Line for Generators/Alternators/Regulators**
 - **Specs for Compatible 6-Volt Г-11/-11A Generator**
 - **Generator Application in Ural (M-72, -72M)/ Dnepr (M-72, -72N, K-750, -750M, Late MT-9, MT-10) Wiring**
- **What Are the PP-1/-30/-31/-31A Regulators?**
 - **External Voltage Regulator for Г-11/-11A Generator (7-Amp/45-Watt)**
 - **Electro-Magnetic (Relay-Type) Design**
 - **Years of Regulator Application: 1941 -to- 1963**
 - **First 6-Volt Russian Motorcycle Regulators**
 - **Later Superseded by PP-302 Regulator in 1963**
- **How Does It Work?**
 - **Regulates Generator Output Voltage to 6-Volts**
 - **Supplies Exciter Current to Vary Stator Magnetic Field**
 - **Provides Constant Voltage Regardless of Rotor Speed and Load**
- **Circuit Description and Operation**
- **Replacement**
 - **Replace PP-1 with PP-30/ -31/ -31A, Available over Internet**

The Relay-Regulator (PP-1, a.k.a RR-1) was the first 6-Volt regulator used on Ural motorcycles.

Types of Generators/Alternators for Ural (Урал) and Dnepr (Днепр) (01/10)

eafranke@tampabay.rr.com

Generator/ Alternator	Type	Vintage	Nominal Voltage	Current	Nominal Power	Regulator	Motorcycles	
							Ural(IMZ)	Dnepr (KMZ)
Г-11 (G-11) (P/N: 72181)	DC Generator	1941- 1951	6-Volt (7-Volt)	7-Amp	45-Watts	PP-1 PP-31 (1950)	M-72	Not Used
Г-11А (G-11A) (P/N: 72181-A)	DC Generator	1952- 1957	6-Volt (7-Volt)	7-Amp	45-Watts	PP-30 PP-31 (1950) PP-31A (1956)	M-72, M-72M, M-61	M-72, M-72N, early K-750, K-750M
Г-414 (G-414) (P/N: 750181)	DC Generator	1957- 1974	6-Volt (7-Volt)	10-Amp	65-Watts	PP-31A (1956) PP-302 (1963) PP-302A	M-62, M-63, M-66	K-650, later K-750, K-750M, MW-750, MW-750M, MT-8, MT-9, MT-12
Г-424 (G-424) (P/N: 3701000)	Alternator (Built-in Rectifier)	1974- 1998	12-Volt (14-Volt)	11-Amp (aka 14-A)	150-Watts	PP-302A PP-330 33.3702 (1992)	M-67, M-67.36, IMZ 8.103 Series	MW-650, MW-650M, MT-10, MT-10.36, MT-11, MT-14, MT-16
Hitachi (Limited Appearance)	Alternator/ Starter	1998- 1998.5	12-Volt (14-Volt)	18-Amp	300-Watts	Internal to Alternator??	IMZ 8.103 and 8.107 "650" Series	Not Used
14.3771 (P/N: 14.3771- 010)	Alternator (Built-in Rectifier & Regulator)	1998.5 -2004	12-Volt (14-Volt)	35-Amp	500-Watts (aka 350-W)	Internal to Alternator (YA212A11E)	IMZ 8.103, 8.103X, 8.123, 8.123X "650 & 750" Series	Not Used
Nippon Denso (P/N: IMZ-8.1037- 18092)	Alternator (Built-in Rectifier & Regulator)	2004- present	12-Volt (14-Volt)	55-Amp	770-Watts	Internal to Alternator (126000-0600)	IMZ 8.103, 8.103X, 8.123, 8.123X "750" Series	Not Used

Notes:

- Nomenclature: The Cyrillic letter "Г" transliterates (Russian-to-Latin) to "G" or "L" or "T." Thus we see Г-414 or G-414 or L-414 or T-414, all for the same part.**
- Cannot use Alternator with discharged battery or without battery.**

Ural (Урал) - Днепр (Днепр) Generator/Alternator Time-Line (12/09)

eafranke@tampabay.rr.com

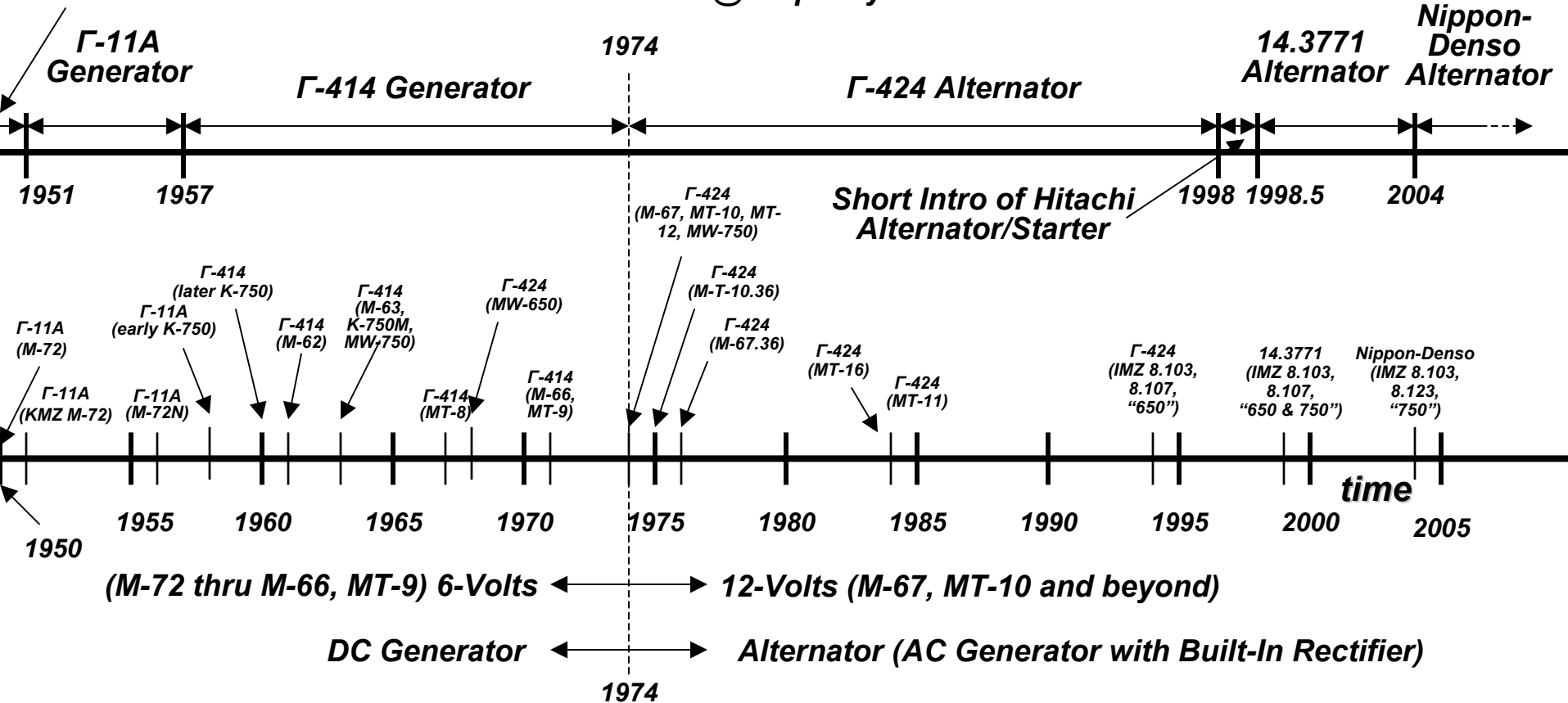

Alternators have progressed in output voltage and power, from the Gamma-11 (G-11) generator of 6-Volts/45-Watts in 1941, the Gamma-11A in 1952, the Gamma-414 of 6-Volts/65-Watt in 1957, the Gamma-424 of 12-Volts/150-Watts in 1974, the 14.3771 of 12-Volts/500-Watts in 1998.5, to the present-day Nippon-Denso alternator of 12-Volts/770-Watts.

Г-11 and Г-11А (G-11 & G-11A) 6-Volt Generator (1941-1957)

- ***6-Volt / 7-Ampere / 45-Watt Generator***
- ***Positive-Ground Casing***
- ***Used on;***
 - ***Ural (IMZ): M-72, M-72M, M-61***
 - ***Dnepr (KMZ): M-72, M-72N, early K-750***
- ***Used in Conjunction with PP-1, PP-30, PP-31 and PP-31A Regulators***



The Г-11 (G-11) generator served as a reliable source for 6-Volts for over 1-1/2 decades.

Relay-Regulator (RR) Description

- **Electro-Magnetic (Relay) Vibration Device.**
 - **Periodically Switches Additional Resistance into Generator Exciter Winding**
- **Consists of Two Relays:**
 - **Voltage Regulator**
 - **Automatic Voltage Control as Number of Revolutions and/or Load Current Changes**
 - **Voltage Regulator Decreases Output Voltage as Load Current Increases**
 - **Reverse-Relay**
 - **Switches Battery In-and-Out**
 - **Automatic Connection/Disconnection of Generator**
- **Factory Set and Housing Is Lead-Sealed**

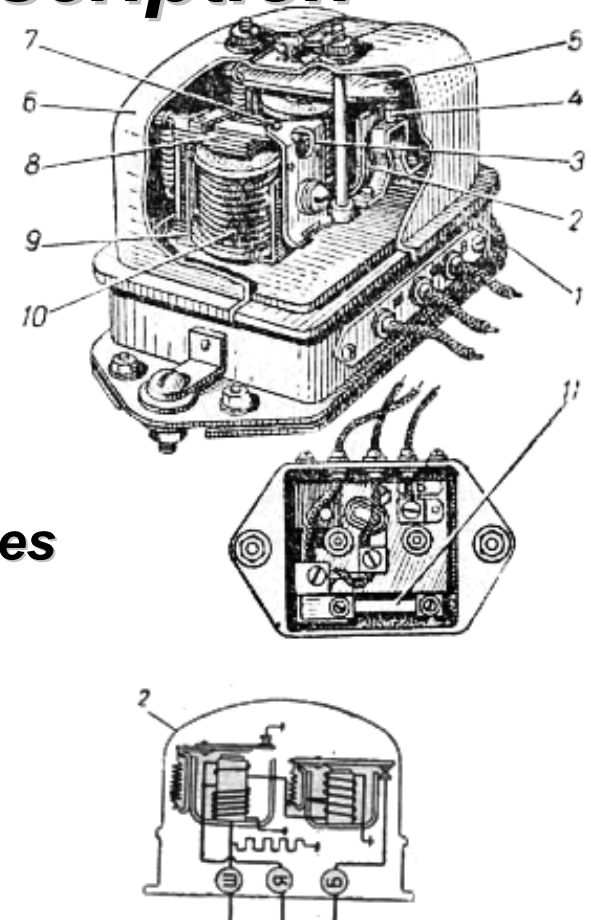

The Γ -11 generator puts out 6.5-Volts at 1,500 rpm and 8.5-Volts at 5,000 rpm (no load). At full-load (7-Amps) the generator produces 6.5-Volts at 2,500 rpm and remains at 7-Volts up to 6,000 rpm. The PP-1 relay-regulator keeps the output voltage between 6.5 and 7.0-Volts.

PP-1 Description

- Consists of Two Relays:
 - Reverse-Relay (POT)
 - Electro-magnet core (4), Yoke (13), Armature (3) with Tension Spring (12), and Contacts 1&2
 - Two Windings: Shunt (ШО) and Series Current (СО)
 - Two-Step Voltage Regulator (PH)
 - Electro-magnet core (7), Armature (6) with Return Spring (8) Two Fixed & One Two-Sided Movable Contacts (5), Series Resistors (9 & 10)
 - Three Windings: Shunt (ШО), Compensatory (КО) and Series Current (СО)

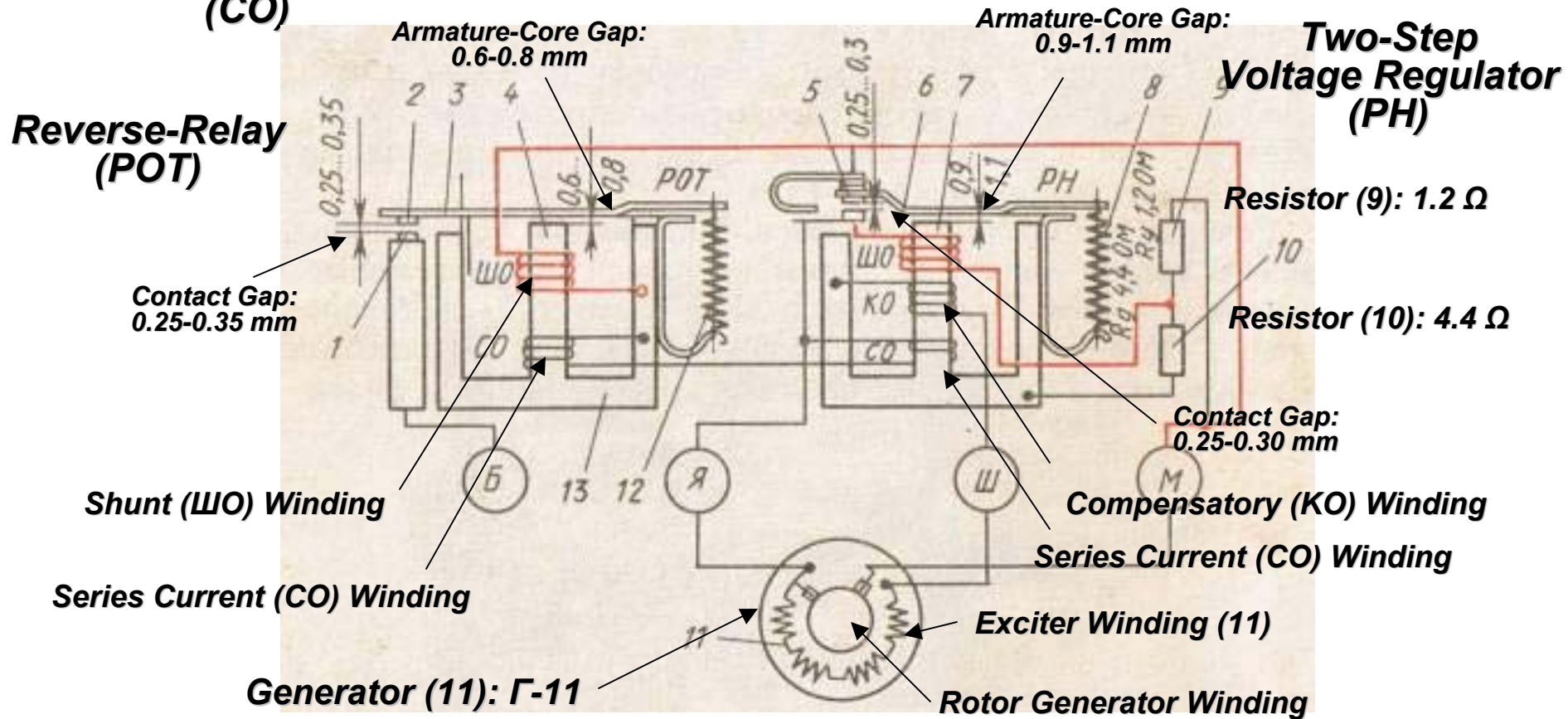

PP-1 Operation

- **Ignition On / Engine Off or Idle (Generator Rotor Not Rotating or Low rpm's)**
 - **Reverse-Relay (POT) Pins 1 & 2: Open**
 - **Two-Way Regulator Relay Contact 5 Pulled by Tension Spring (8) to Upper Fixed-Contact Connected to Case**
 - **Generator Exciter Winding (11) Connected to Body thru Compensation Winding (KO) and Movable Contact 5**
- **With Increasing Generator Speed**
 - **Armature Current Passing thru Series Winding CO Magnetizes Electromagnet Core**
 - **Attracts Armature 3, Connecting Reverse-Relay Contact 2 with Contact 1**
 - **Current Charges Battery and Supplies Ignition/Lighting Circuit**
 - **Under Influence of Increasing Voltage Attracts Armature (6), and Two-Way Regulator Contact 5 in Middle Position**
 - **At Same Time, Two Series Resistors (R9 & R10) Inserted in Series with Generator Exciter Winding 11 and Compensation Winding (KO)**
- **With Further Increase of Rotation Frequency of Generator**
 - **Additional Resistance Prevents Increase of Generator Voltage in Excess of Specified Limit**
 - **Regulator Armature (6) Attracted to Electromagnet and Movable Contact 5 Pulled against Lower Contact, Closing Short-Circuited Generator Excitation Winding**
 - **Generator Voltage Decreases and Armature Returns to Middle Position, and Again to Closed Position with Upper Contact**
 - **Two-Step Voltage Regulator (PH) Armature, Vibrating, Supports Voltage Generator within 6.5 -to- 7-Volts**

PP-30: 6-Volt Regulator



PP-31/-31A 6-Volt Regulators



PP-31



PP-31 A

It is important to identify the exact component used on your Russian motorcycle, so that you can find the correct schematic and secure exact replacement parts.

PP-1 and PP-31 6-Volt Regulators

PP-1

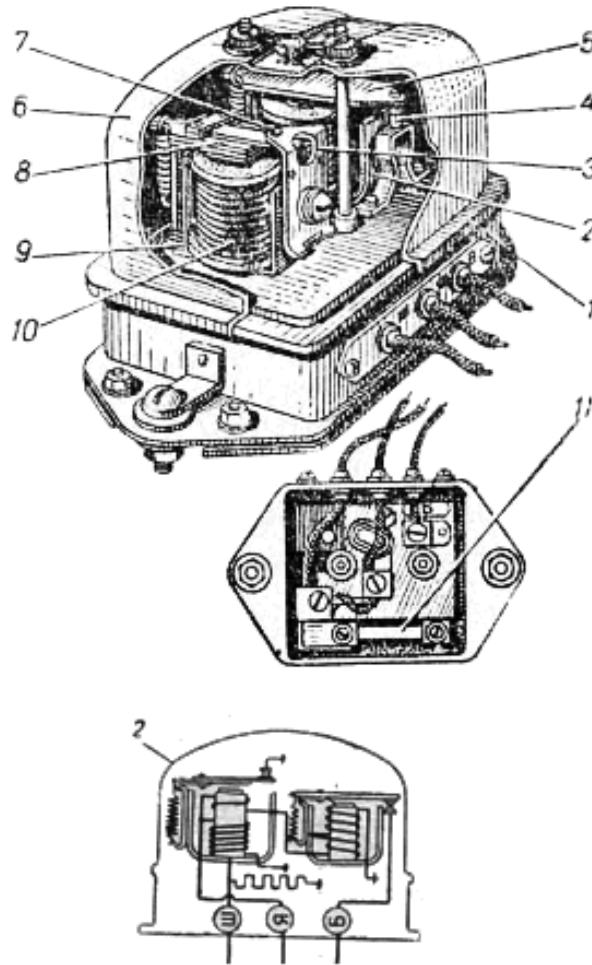

PP-31

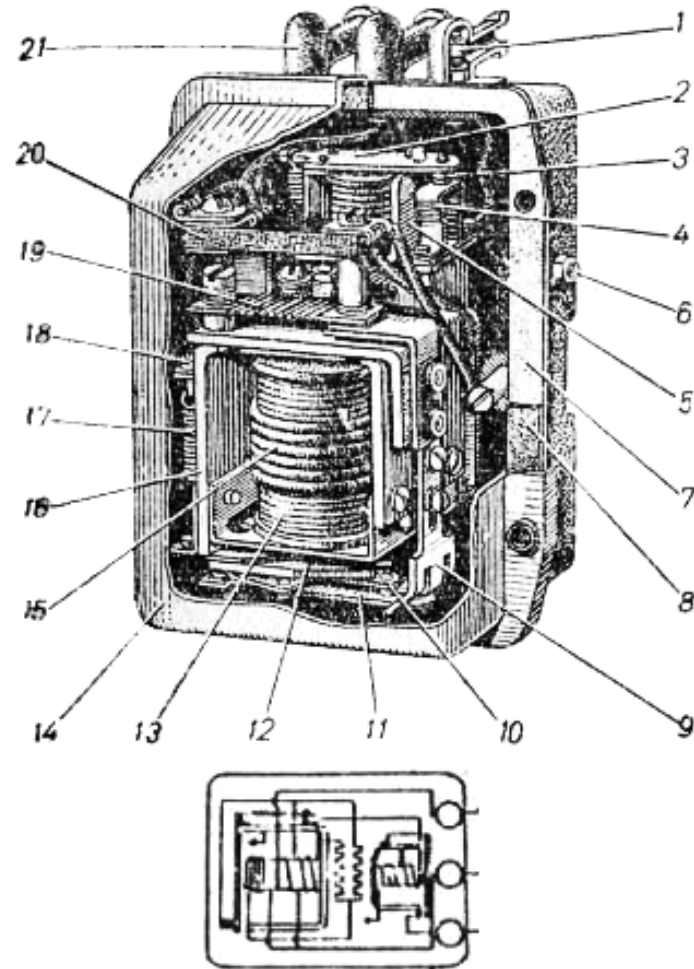

The PP-1 is distinguished from the PP-30/-31 series of regulators in that it has a taller cap with hold-down nuts.

Ural (Урал) M-72 with PP-1 Regulator (pre-1949)

Ural (Урал) M-72 with PP-31 Regulator (post-1949)

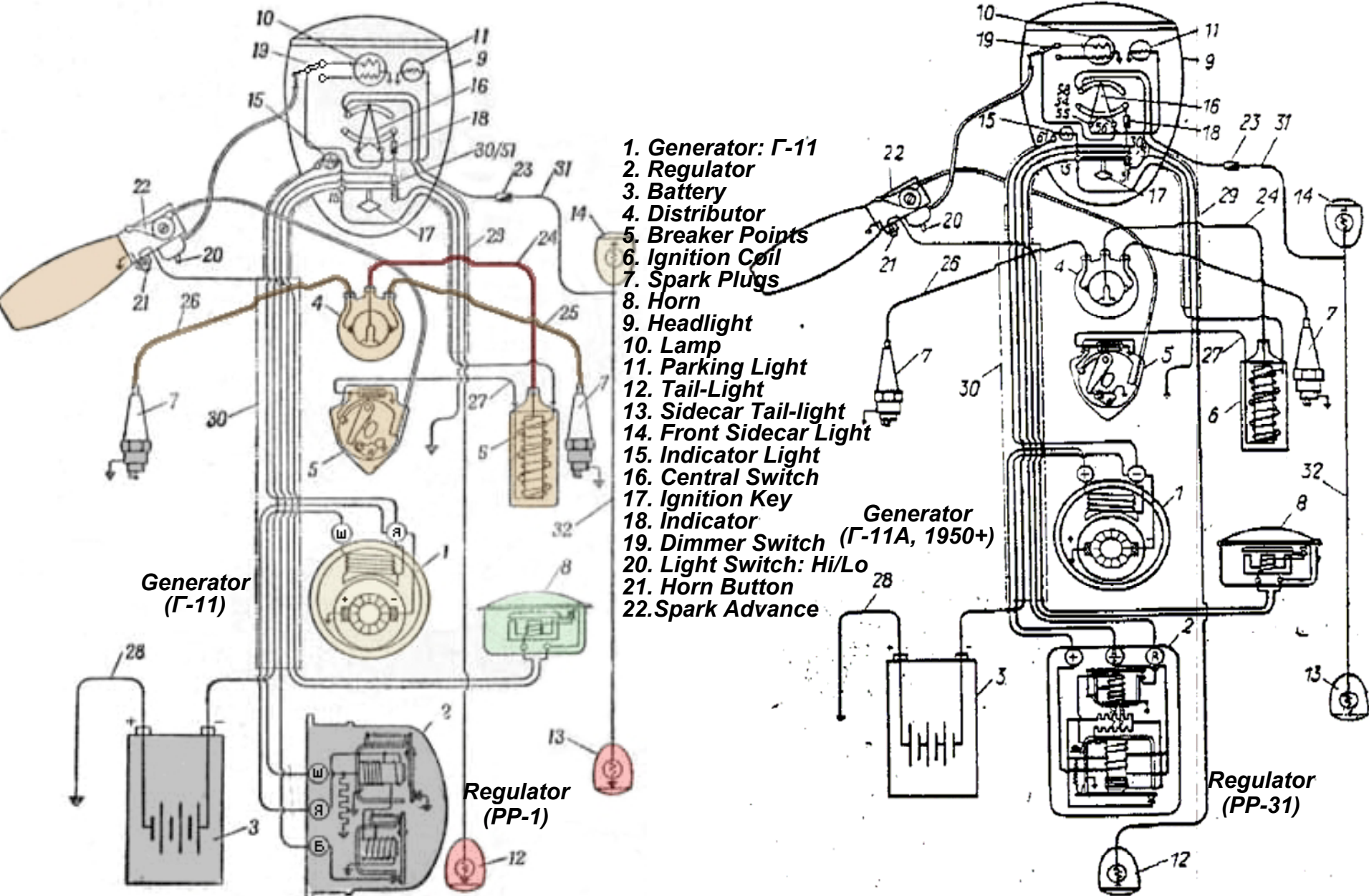

Днепр (Днепр) Early K-750 and K-750M

(with Ignition Coil B2B and Distributor PM-05 for Manual Control of Firing Angle)

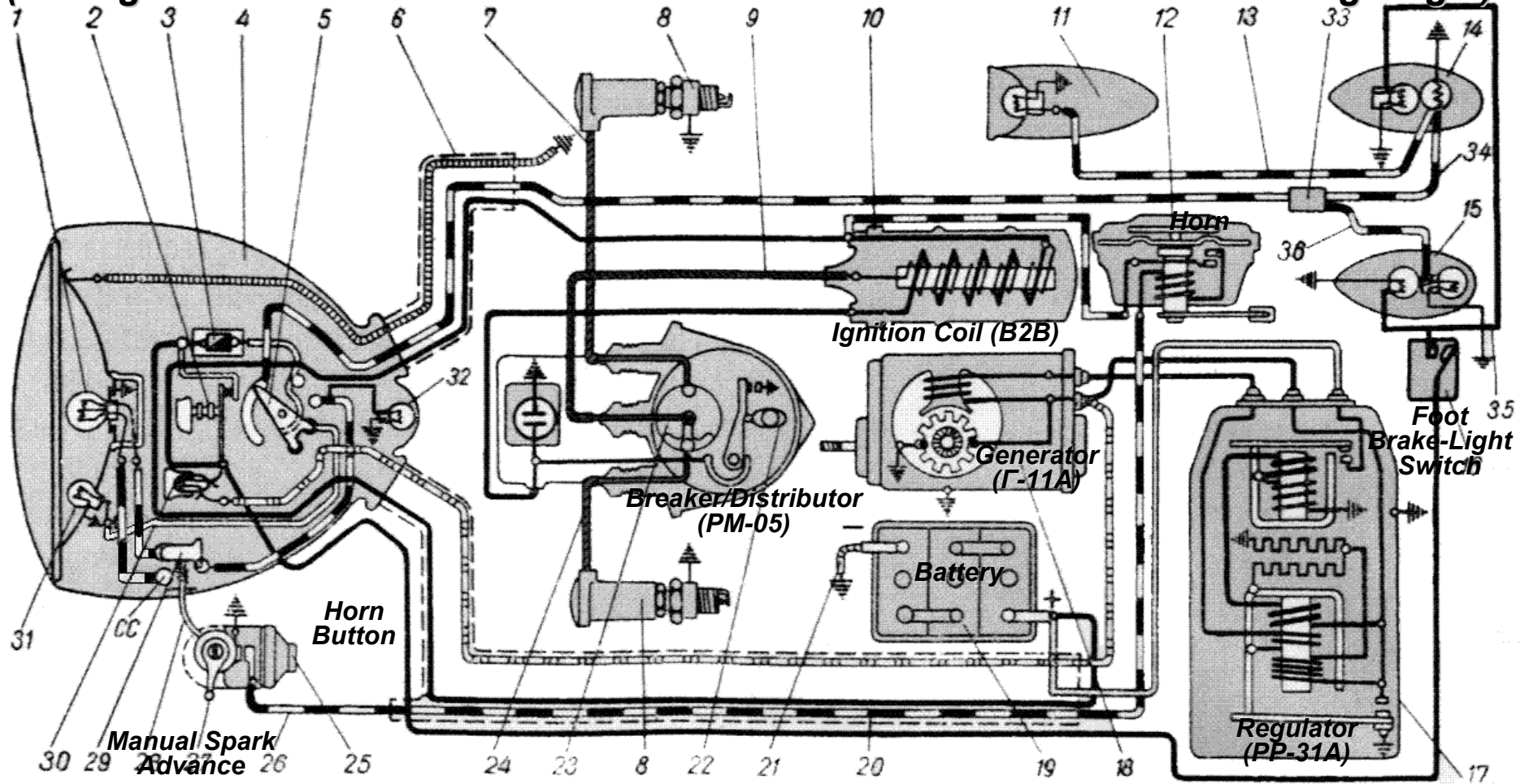

1 - lamp beam and dipped beam, 2 - key 3 - safety 4 - lamp, 5 - central switch, 6 - wire "ground", 7 - high voltage wire, 8 - spark plugs, 9 - high voltage 10 - ignition coil, 11 - front light stroller, 12 - horn, 13 - wire front canopy sidecar, 14 - tail light sidecar, 15 - tail lamp of motorcycle, 16 - gauge stoplight, 17 - Relay-regulator, 18 - generator, 19 - battery, 20 - Low voltage wiring loom, 21 - the wire "battery - ground, 22 - breaker, 23 - valve, 24 - high voltage wire and 25 - button signal 26 - wire signal 27 - advance ignition; 28 - cord switch driving and parking light, 29 - switch to driving and parking light, 30 - control lamp, 31 - the parking light bulb, 32 - lamp illuminated; 33 - Connecting Jack wires, 34 - cable sidecar lamps, 35 - wire from the sensor to Stop lamp, 36 - wire from the connector to the lamp lighting plate

Днепр (Днепр) Early MT-9: Manual Control of Firing Angle ***(B2B Ignition Coil and PM-05 Breaker/Distributor)***

Later MT-9: Automatic Spark Advance and MT-10 ***(B201A Ignition Coil and PM-302 Breaker)***

